

You must have a limit switch with a plastic top!!!!

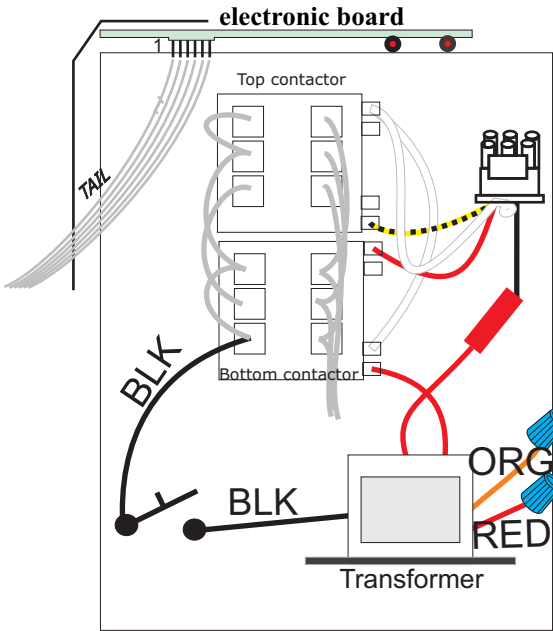

You must follow all steps to insure proper operation. Failure to do so could result in injury to you or damage to the remote and/or the lift. It is very important you must have a limit switch attached for this unit to work properly it is also against the National Electric Code to have an Auto-Stop(Run) unit without a limit switch. We have four standard limit switch systems: KCLS, KELS, KFLS, and KRLS.

Tools needed: Phillips & regular screwdriver, needle nose pliers, wire cutter, drill and 5/8 in bit, wire strippers, magic marker, 3 blue wire nuts and tape. Your box on the dock must have a date later than 03/07 inside the door and your transmitter needs to be yellow with three blue buttons.

1. First check that all motors go up when up is selected and down when using the manual switch turn off main power and make sure the unit does not work. Unplug tail from the face card to the board. Pull on black housing 1.
2. If upgrading you will need to cut J1 if it is not cut then the Auto-Stop mode will not work. See the picture and cut J1 wire on the electronic board with wire cutters.
3. Press the 3 pin connectors into the board on the right-hand side use the top 3 pins.
4. Attach the limit switch to the lift according to its instructions.
5. Route the wire from the limit switch back to the GEM box. You might have to drill a 5/8 inch hole in the bottom of the box. Fasten the cord grip, push wire through the new hole and cut off the excess wire you should leave enough wire to get to the new orange pin three wire harness.
6. Cut off 3 inches of the black insulation to expose the red, black and blue wires.
7. Use wire nuts and connect wires color to color inside the GEM box.

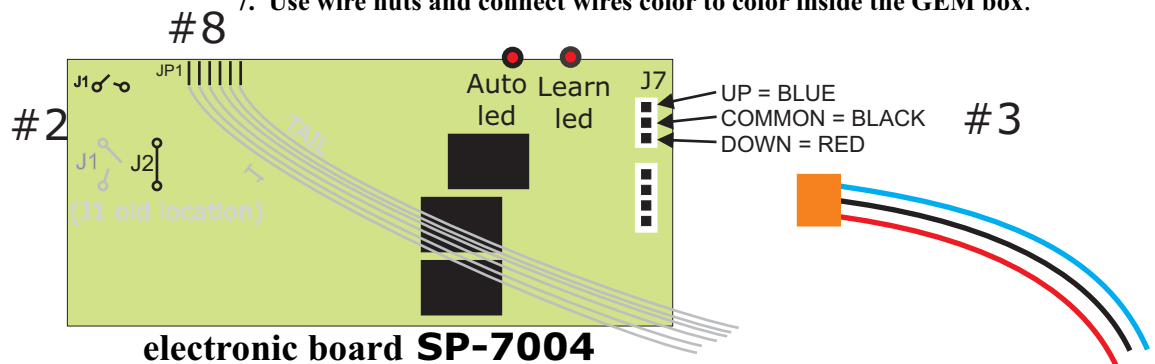

8. Attach the membrane switch tail to the board so the JP1 and 1 on tail match up 1 should go on the left side of the board. Press the learn button and the learn LED should light up for 6 seconds. If the LED does not light retry the tail. Screw face card to box.

9. Turn power on to your unit then press the Auto-Stop(run) button and the Auto-Stop LED should turn on. If it doesn't turn on cut J1 and reread instructions. Cycle power and try again (J1 in gray is the older board location).

10. When you turn on the GEM system you should see a the LED flash. Make sure the lift stops and flashes fast for the up limit and flashes slow when your at the lowest limit. If hooked up backwards the unit will stop the first time it hit the limit but if that direction is pressed again it will run in that direction for 25 seconds and then stop.

11. Your unit is now an Auto-Stop unit it should run up to the limits when the up or down is pressed one time. Add an "A" to the part number on the door so a GR2 will now be a GR2A, you should also add a date to know when you made the changes. The auto-stop light will flash quickly for an up limit and slowly for a down limit. This unit will not work until the limit switches are attached. To Clear memory of all transmitters, press and hold the CLEAR button for seven seconds. The LED will flash then let go of the learn button. Test to see if a transmitter works it should not.

If you have any comments, questions or complaints please contact us. info@gemremotes.com 239-642-0873

HiTide connections: If you are hooking up to a 4 wire limit switch system then you must join 2 wires: 1 from up limit and 1 from down limit (HiTide black and blue) and attach to the GEM's Blk with a wire nut. Then attach the GEM blue (up) to HT gold (up). Then the GEM red (down) to HT red (down)wire.

Build notes: Org 3 pin: red, blk & blue, 1 Cord grip always send limit switch instructions.