

March 2007 to current

GR2

GR2F1

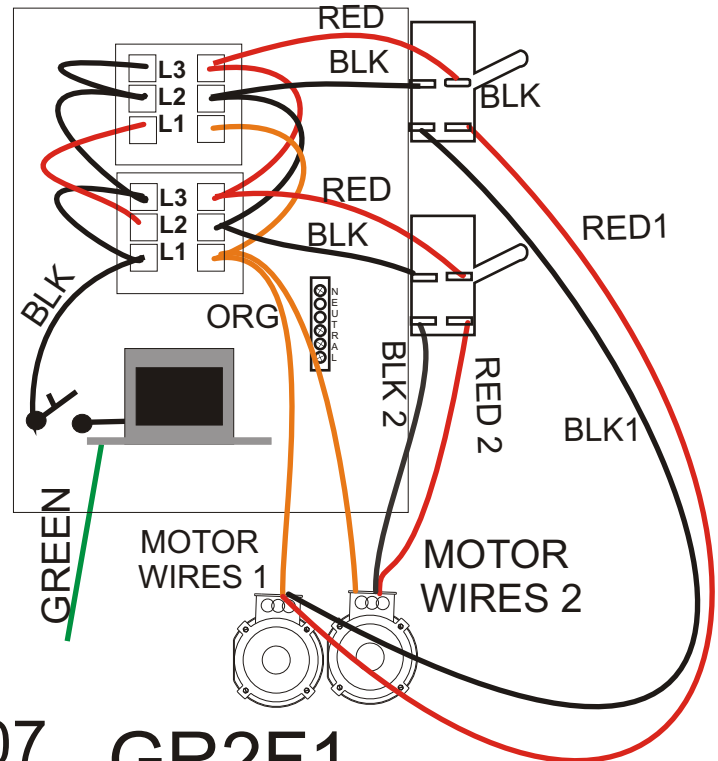
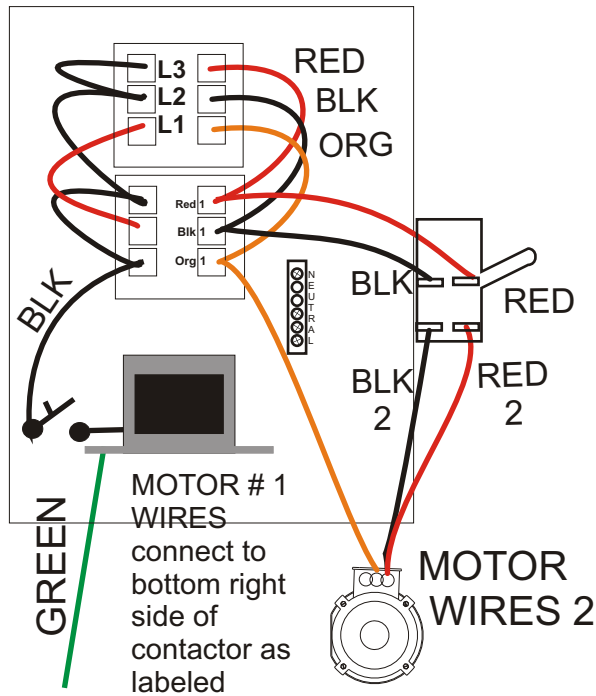

GR2

1985-2007

GR2F1

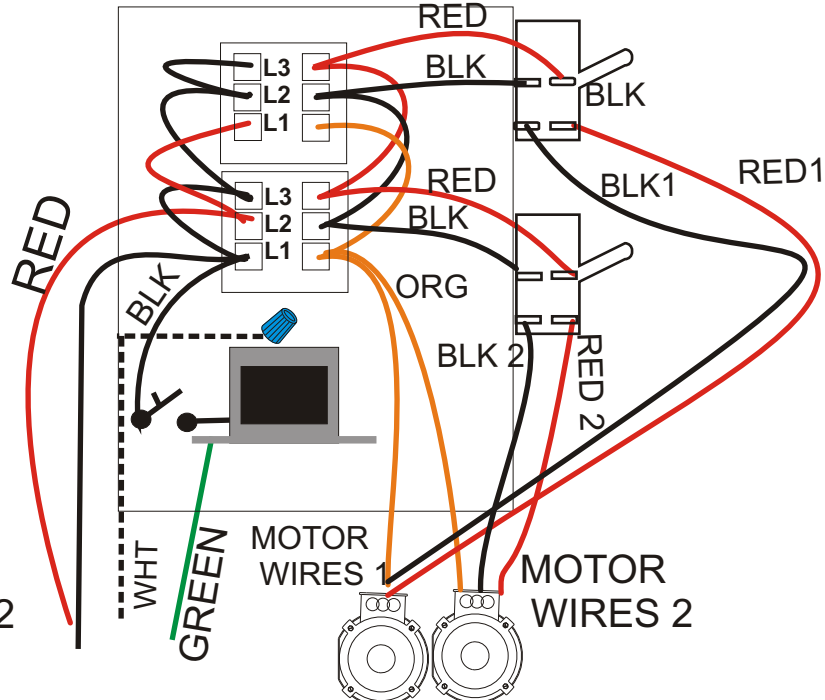
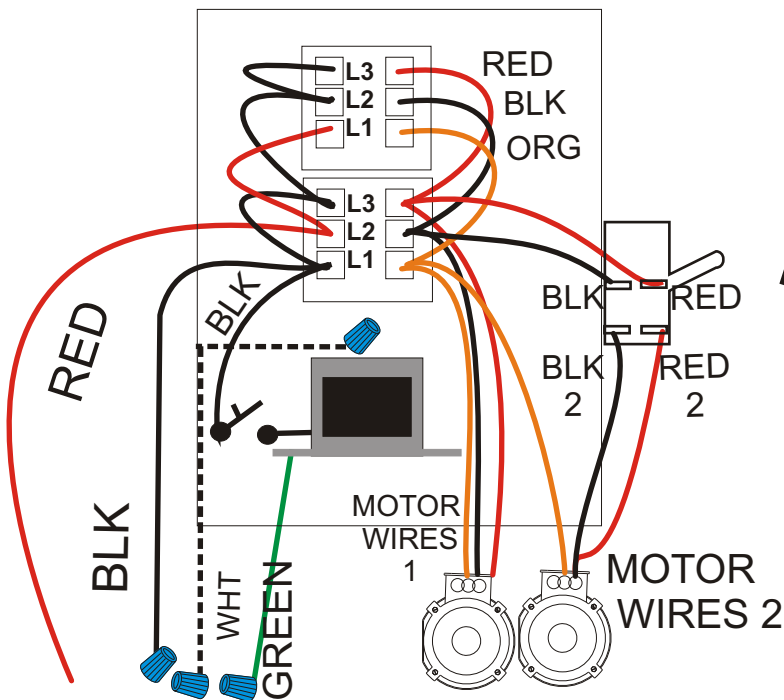

Tools needed: Philips and regular screw driver, needle nose pliers, wire crimper, and crescent wrench drill and drill bit (1/2).

1. Turn off power to dock, check that unit does not work.
2. Remove 4 screws to gain access to controls. Remove switches from old face plate and replace with new. Drill a hole 1.5 inches below the Level switch for #2(pre 2007 units) or drill 2 holes on right side of box above clasp.
3. You will need to remove Motor #1 wires from the contactor and place them on the bottom of the new #1 switch. Red1 and Black1 wires going to motor 1 keep black wire on one side and red wires on the other side. Attach red and black wire to the top of the switches and match color to color on the top contactor.

Parts: 1boot, 2(4motor)switch, 1+2 on/off label, red & blk 5.5 jumper and 2 red & 2 Blk 10 inch motor wires.